

# BLACKMER PARTS LIST

**PUMP MODELS: TXD3E, TXSD3E** (Double Ended Shafts)  
**TX3E, TXS3E** (Single Ended Shafts)

Keep with Instructions 201-A00 for Installation, Operation and Maintenance

Section 201  
Effective Apr 2009  
Replaces Mar 2008

This doc is for TXSD3E & TXS3E discontinued Jan 2012  
TXS equivalent may be specified via a TX pump with options

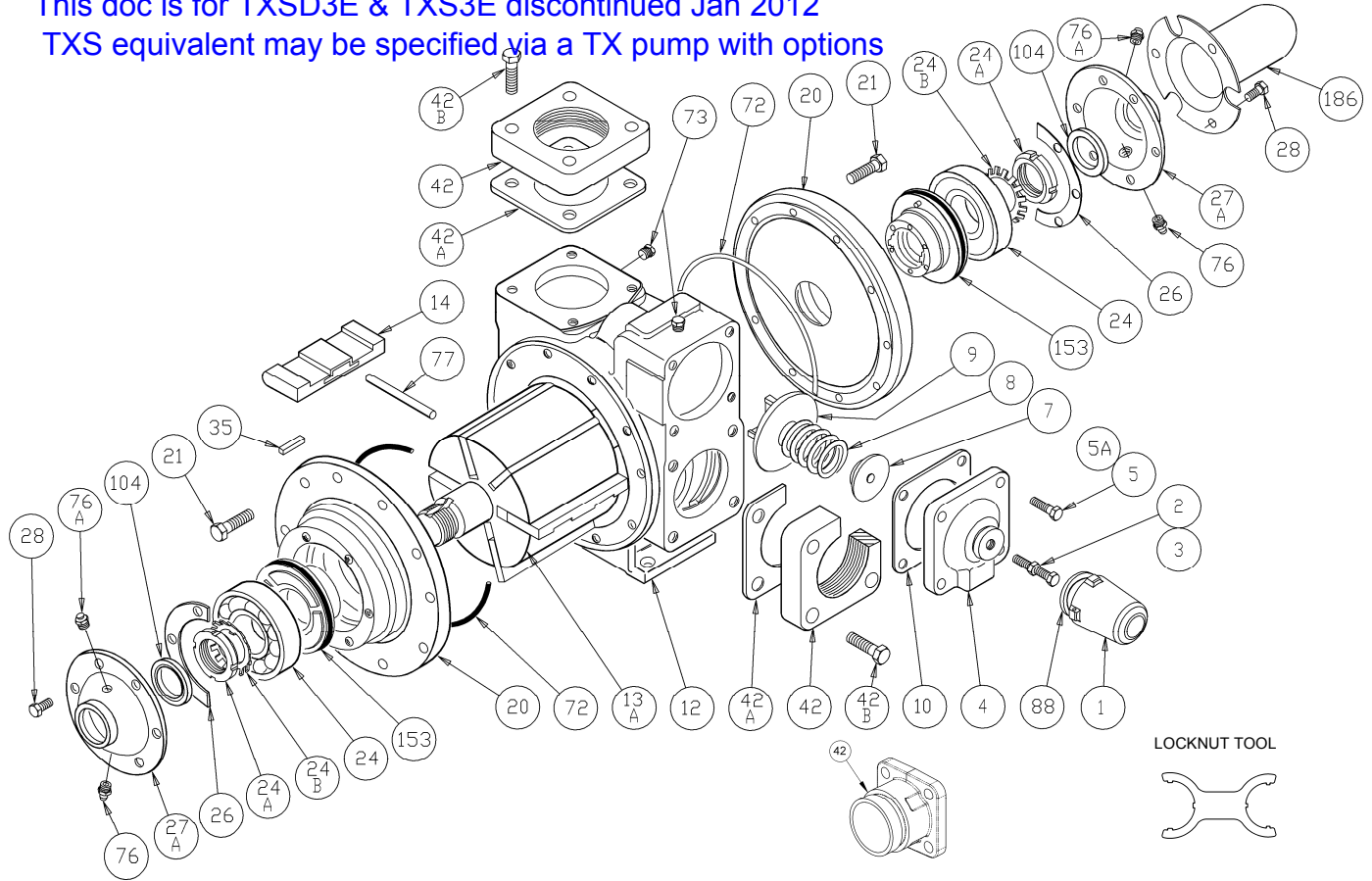

Ref. No.	Description	Parts Per Pump	Part No.	Ref. No.	Description	Parts Per Pump	Part No.
1	Cap – Relief Valve (R/V)	1	413957	26	Gasket – Bearing Cover	2	<sup>1</sup> 381817
2	Adjusting Screw – R/V	1	431808	27A	Bearing Cover	1 - 2	041815
3	Locknut – Adjusting Screw	1	922923		Bearing Cover - Outboard	0 – 1	041817
4	Cover – R/V	1	411807	28	Capscrews – Bearing Cover	12	920285
5	Capscrew – R/V Cover	3	920331	35	Key – Shaft	1	<sup>1</sup> 909178
5A	Capscrew w / Hole – R/V Cover	1	920330	42 –	Flanges, Flange Gaskets / Orings, and Flange Capscrews		See Backside
7	Spring Guide – R/V	1	421805	42C			
8	Spring – R/V (51-110 psi)(Std.)	1	471806		O-Ring - Head (Buna-N) (Std. TXD)		<sup>1</sup> 701944
	Spring – R/V (111-125 psi)		471809	72	O-Ring - Head (FKM) (Std. TXSD)	2	711938
9	Valve - R/V (Std. TXD) <sup>3</sup>	1	451807		O-Ring – Head (PTFE)		702233
	Valve - R/V (Nickel Plated) (Std. TXSD)		451808	73	Gage Plug	2	908198
10	Gasket – R/V Cover	1	<sup>1</sup> 531803	76	Grease Fitting	2	317815
12	Cylinder	1	021805	76A	Grease Relief Fitting	2	701992
13A	Rotor & Shaft Asy. - Double Ended <sup>2</sup>	1	261837	77	Push Rod	3	<sup>1</sup> 121807
	Rotor & Shaft Asy. - Single Ended <sup>2</sup>		261839	88	Gasket - R/V Cap	1	<sup>1</sup> 533908
14	Vane – Duravane	6	<sup>1</sup> 091819	104	Grease Seal	1 - 2	<sup>1</sup> 331908
20	Head	2	031815	186	Shaft Protector	0 - 1	341801
21	Capscrews – Head	20	920369		Air Valve Kit		891798
24	Ball Bearing	2	<sup>1</sup> 903172		Tool - Locknut		903091
24A	Locknut – Bearing	2	903523		Kit – Maintenance (TXD3E only)		898952
24B	Lockwasher - Bearing	2	<sup>1</sup> 903524				

<sup>1</sup> Included in Maintenance Kit    <sup>2</sup> Includes ref. Nos. 24A & 24B

<sup>3</sup> For Piston Style Air Operated RV see IOM 201-G00, Diaphragm Air RV – 201-F00, DMX Diaphragm RV – 201B-B00.

**MECHANICAL SEALS**

REF. NO.	PART NAME	PARTS PER PUMP	PART NO.
153	Mechanical Seal Complete - <b>Std. TXD</b> Cast Iron Stationary Seat, Carbon Seal Face, Buna-N O-Rings. (INCN)	2	1 331880
	Mechanical Seal Complete - <b>Std. TXSD</b> Cast Iron Stationary Seat, FKM O-Rings, Carbon Seal Face. (IVCV)		331883
	Mechanical Seal Complete - Cast Iron Stationary Seat, PTFE O-Ring, Carbon Seal Face w/ PTFE Seal Ring. (IACT)		331873
153D	O-Ring - Stationary (Buna-N)	2	701936
	O-Ring - Stationary (FKM)		711931
	O-Ring - Stationary (PTFE)		702080
153L	O-Ring - Rotating (Buna-N)	2	711912
	O-Ring - Rotating (FKM)		701962
	Seal Ring - Rotating (PTFE)		**

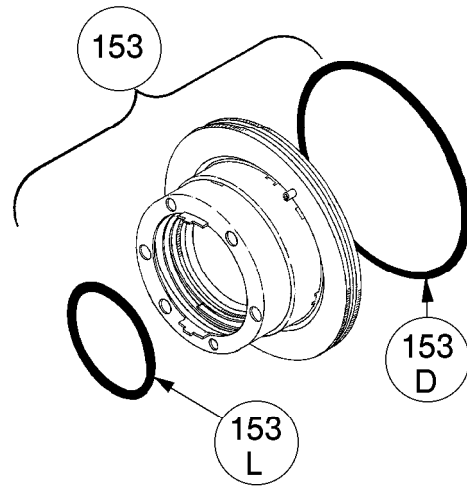

<sup>1</sup> Included in Maintenance Kit

\*\* PTFE Rotating Seal Ring is not available as a separate part.

**FLANGES**

REF. NO.	PART NAME	PARTS PER PUMP	PART NO.
42	Flange – 3" NPT	1 – 2	651803
	Flange – 3" Weld		655102
	Flange – 3" Victaulic		655120
42A	Gasket – Flange, NPT and Weld	0 – 2	<sup>1</sup> 381816
42B	Capscrews – NPT Flange	4 – 8	920532
	Capscrews – Weld & Victaulic Flange		920510
42C	O-Ring – Victaulic Flange (Buna-N)	0 – 2	702002
	O-Ring – Victaulic Flange (FKM)		711931
	O-Ring – Victaulic Flange (PTFE)		702080

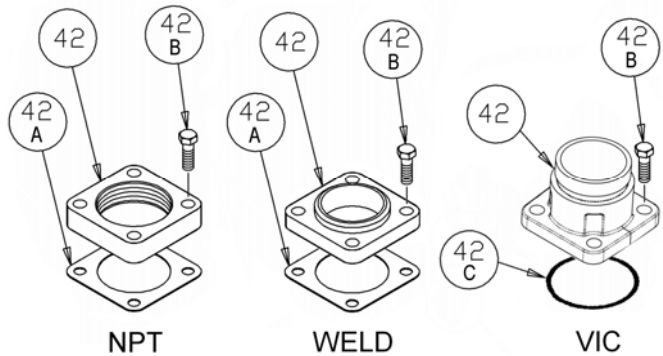

**OPTIONAL HYDRAULIC MOTOR ADAPTER**

REF. NO.	PART NAME	PARTS PER PUMP	PART NO. 1-1/4" Hyd Motor Shaft	PART NO. 1" Hyd Motor Shaft
	<b>Hydraulic Motor Adapter Kit *</b>		895140	895143
26A	Gasket – Hydraulic Motor Adapter	1	381817	381817
28A	Capscrew – Hydraulic Motor Adapter / Head	6	920369	920369
34	Coupling w/ Setscrew – straight key hydraulic motor	1	906967	906990
35	Key – Coupling	1	909184	909184
76	Grease Fitting	1	317815	317815
76A	Grease Relief Fitting	1	701992	701992
135	Hydraulic Motor Adapter – SAE A Flange	1	041831	041831
135A	Capscrew – Adapter / Motor	2	920510	920510

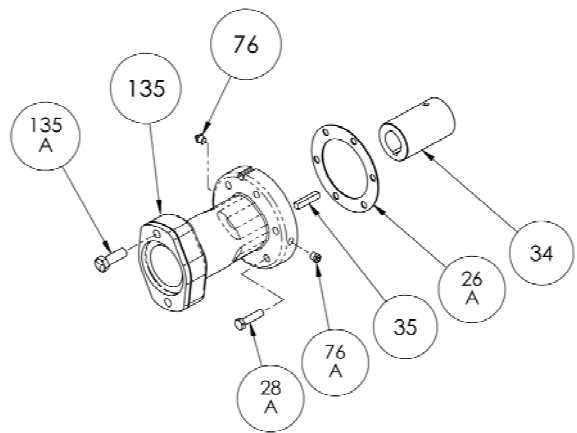

\* Hydraulic Motor Adapter Kits shipped prior to Spring 2002 were of a two piece design – refer to page 206-B00.



1809 Century Avenue, Grand Rapids, Michigan 49503-1530, U.S.A.  
 Telephone: (616) 241-1611 / Fax: (616) 241-3752  
 E-Mail: blackmer@blackmer.com / Internet: www.blackmer.com