

BLACKMER ENTERPRISE BLOWER PARTS LIST

MODELS: E352, E502

Discontinued Models

(See Instructions 288/B for Installation, Operation and Maintenance)

969803

PARTS LIST NO. 208-B01_sep01

Section 208

Effective Sept 2001

Replaces 288/B1 Aug 1998

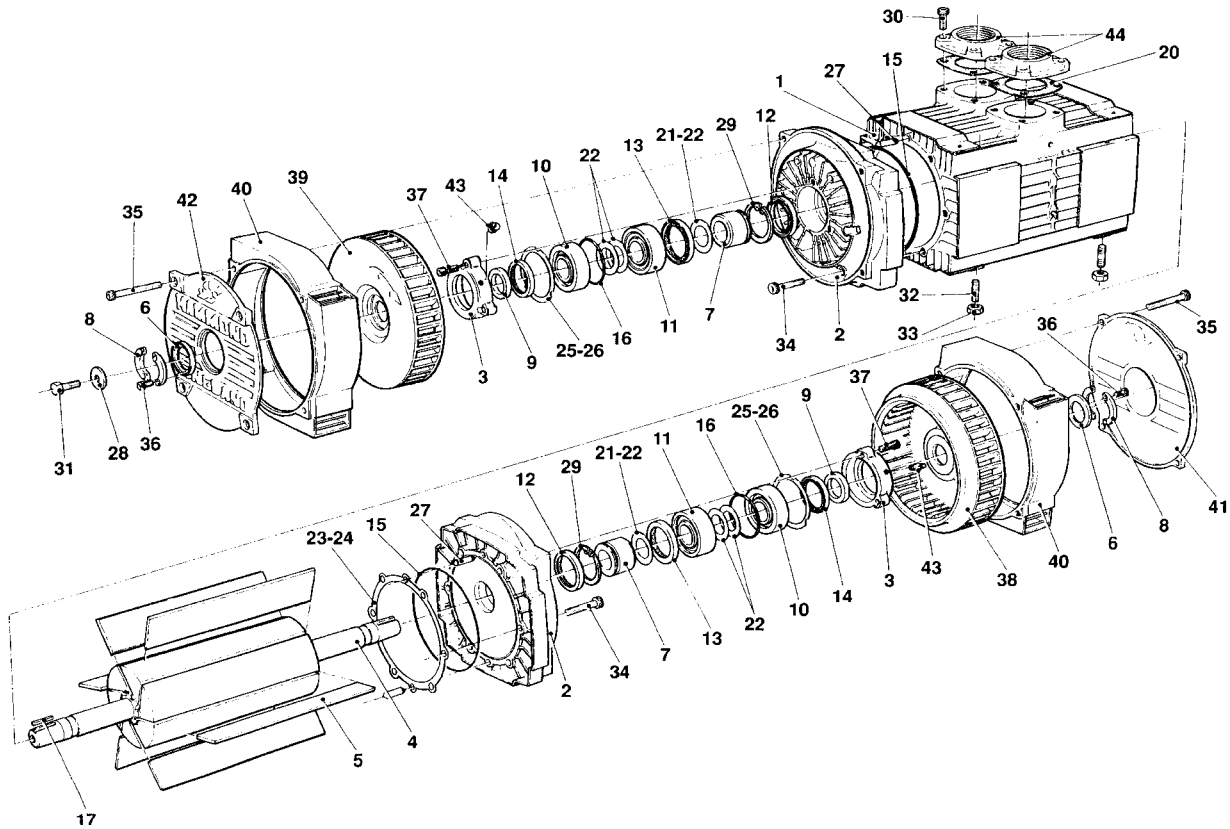

REF. NO.	DESCRIPTION	QTY.	PART NO.	REF. NO.	DESCRIPTION	QTY.	PART NO.
1	Body – E352	1	212.508	25	Bearing Cap Shim (0.05mm)	A/R	021.025
	Body – E502		212.510	26	Bearing Cap Shim (0.12mm)	A/R	021.026
2	Sideplate	2	008.008	27	Dowel Pin	4	022.004
3	Bearing Cap	2	009.042	28	Washer	1	023.016
4	Rotor – E352	1	011.027	29	Circlip	2	023.041
	Rotor – E502		011.029	30	Capscrew (M10 x 25)	8	024.009
5	Blade – E352	6	013.046	31	Setscrew (M12 x 25) (Hex Head)	1	024.025
	Blade – E502		013.053	32	Stud (M12 x 30 x 18)	4	024.031
6	Thrust Sleeve	2	016.028	33	Nut (M12)	4	024.032
7	Distance Sleeve	2	016.043	34	Capscrew (M10 x 70)	12	024.059
8	Split Sleeve	2 pr.	016.044	35	Capscrew (M10 x 100)	8	024.060
9	Fan Sleeve	2	016.073	36	Capscrew (M8 x 20)	8	024.061
10	Bearing - Angular Contact	2	017.005	37	Capscrew (M10x 35)	6	024.031
11	Bearing - Roller	2	017.009	38	Fan - Clockwise	1	025.007
12	Wiper Seal	2	018.027	39	Fan - Counterclockwise	1	025.008
13	Oil Seal - Sideplate	2	018.028	40	Cowl	2	026.004
14	Oil Seal - Bearing Cap	2	018.065	41	Cover - Non-Drive End	1	029.007
15	O-Ring - Sideplate	2	018.071	42	Cover - Drive End	1	029.008
16	O-Ring - Bearing Cap	2	018.082	43	Grease Nipple (45°)	2	055.014
17	Shaft Key	1	020.007	44	Flange - 2 1/2" NPT	2	056.018
20	Gasket - Flange	2	021.052		Flange - 3" NPT		056.013
21	Shaft Shim (0.05mm)	A/R	021.017		Areoshell Grease (not shown)	1 tube	889840
22	Shaft Shim (0.12mm)	4 (min)	021.018		Repair Kit – E352		207.547
23	Body Shim (0.05mm)	A/R	021.023		Repair Kit – E502		207.548
24	Body Shim (0.12mm)	A/R	021.024		Service Kit – E352		207.530
					Service Kit – E502		207.531

* Parts Included in Repair Kit.

** Parts Included in Service Kit.

A/R = As Required

PILOT OPERATED RELIEF / CHECK VALVE

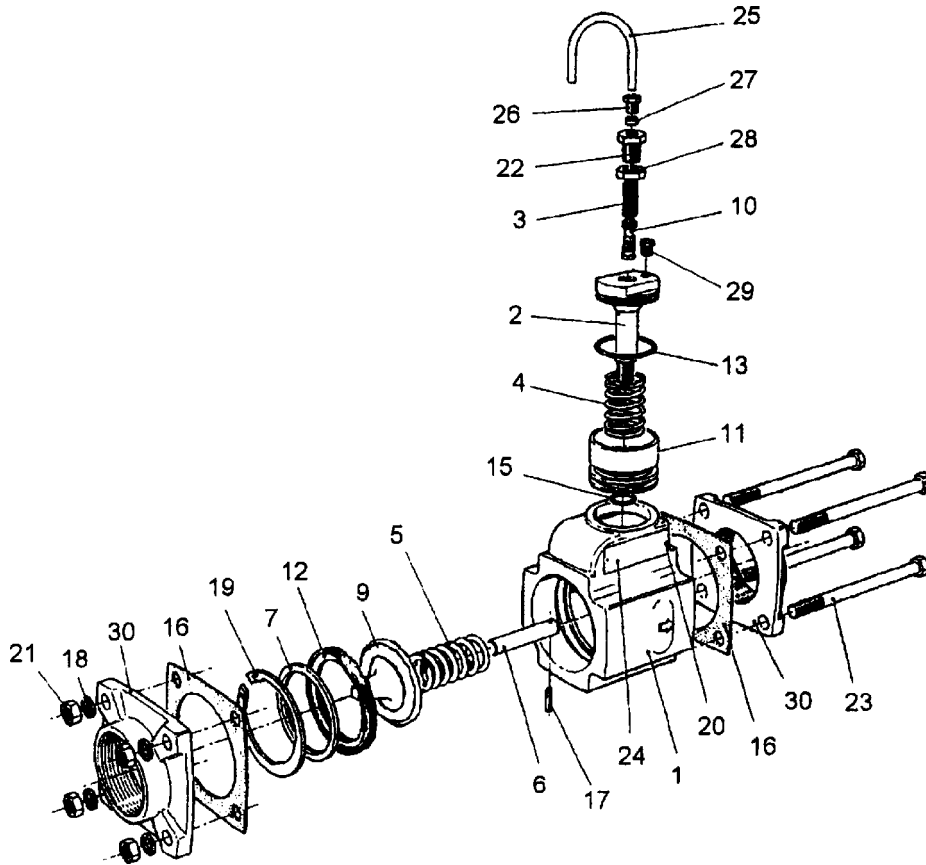

REF. NO.	DESCRIPTION	QTY.	PART NO.	REF. NO.	DESCRIPTION	QTY.	PART NO.
1	Body – Check Valve	1	007.117	17	Tension Pin	1	022.010
2	Body – Relief Valve	1	007.123	18	Spring Washer (M10)	4	023.017
3	Spring – Pilot Valve	1	010.010	19	Circlip	1	023.030
4	Spring – Relief Valve	1	010.012	20	Drive Screw (not shown)	2	024.015
5	Spring – Check Valve	1	010.019	21	Nut (M10)	4	024.024
6	Shaft	1	012.026	22	Adjusting Screw - Valve	1	024.125
7	Check Valve Seat	1	016.056	23	Capscrew (M10 x 140) (Hex Head)	4	024.132
8	Bushing (not shown)	1	016.057	24	Name Plate (not shown)	1	037.001
9	Check Valve	1	014.063	25	Pipe – ¼" O.D.	1	040.073
10	Pilot Valve	1	014.066	26	Tubing Nut – ¼" O.D.	1	055.031
11	Relief Valve	1	016.097	27	Olive – ¼"	1	055.032
12	Seal	1	018.055	28	Locknut	1	055.037
13	O-Ring	1	018.070	29	Plug – 1/8" BSP	1	055.042
15	O-Ring	1	018.104	30	Flange – 2 ½" NPT	2	056.018
16	Gasket	2	021.052		Flange – 3" NPT		056.013

INLET FILTER KIT

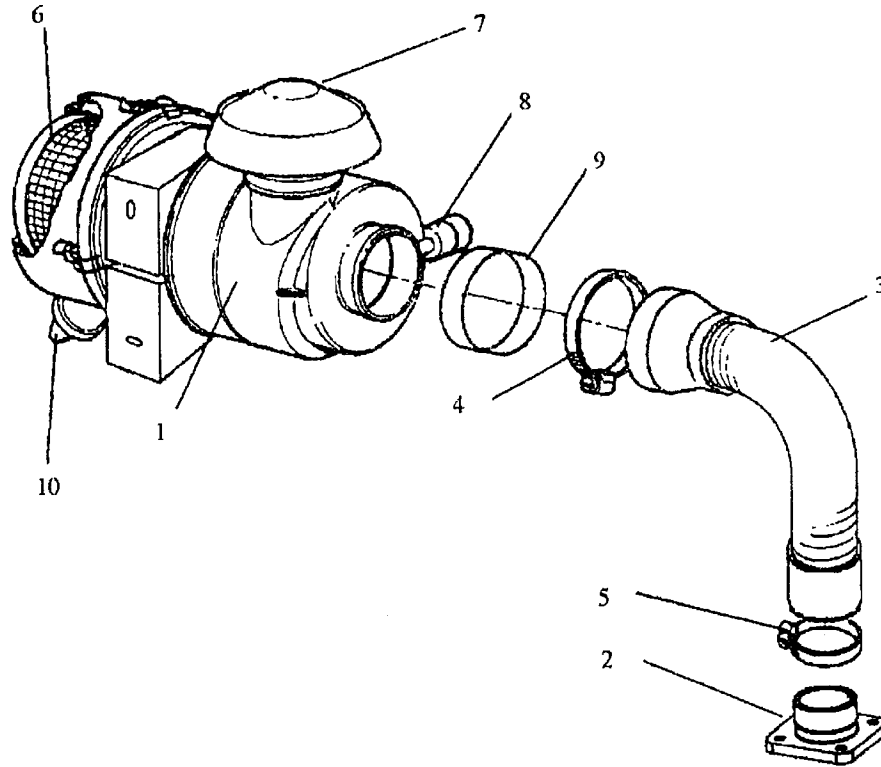

REF. NO.	DESCRIPTION	QTY.	E352 PART NO.	E502 PART NO.
1	Inlet Filter Unit	1	045.107	045.052
2	Flanged Connector	1	056.049	056.049
3	Flexible Hose	1	040.034	040.034
4	Hose Clip	1	023.087	023.087
5	Hose Clip	1	023.020	023.020
6	Filter Element	1	045.108	045.053
7	Rain Cap	1	045.112	045.074
8	Filter Restriction Indicator	1	045.021	045.021
9	Rubber Band	1	045.113	N/A
10	Dump Valve	1	045.114	045.114

N/A = Not Applicable

ACCESSORIES

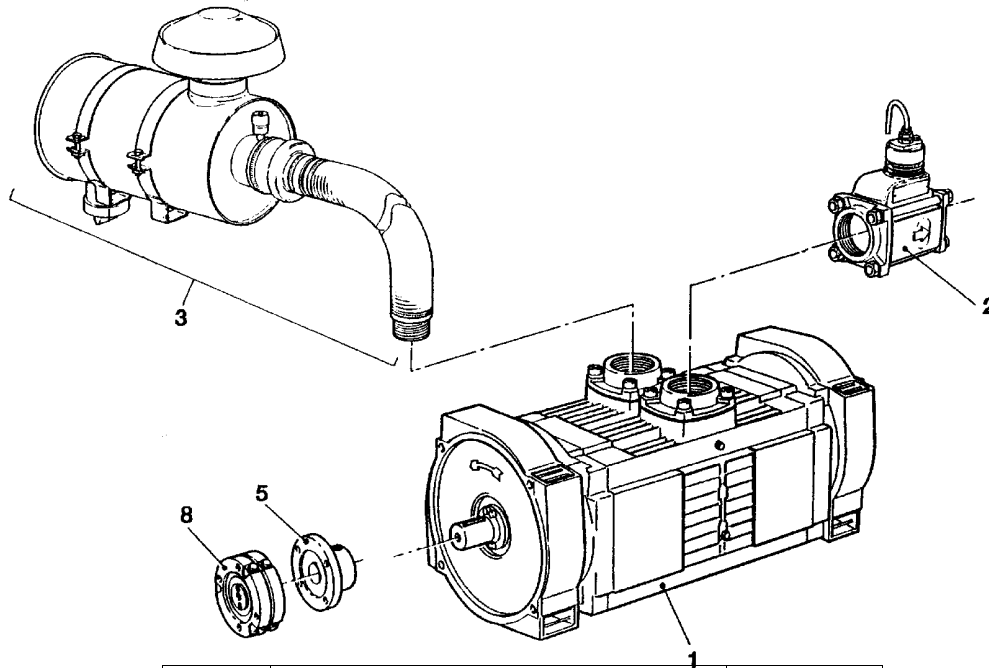

REF. NO.	DESCRIPTION	PART NO.
1	Compressor – E352 *	206.503
	Compressor – E502 *	206.501
2	Check/Relief Valve – Pilot Operated	207.510
3	Inlet Filter Kit – E352	207.539
	Inlet Filter Kit – E502	207.505
5	Drive Flange (1300)	057.007
	Drive Flange (1400)	057.008
8	Coupling Shear Spacer (1300)	222.504
	Mounting Bracket (Not Shown)	041.146

*Compressor includes Drive Flange, less flanges.

SERVICE TOOLS

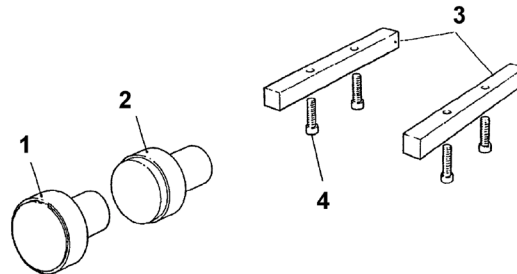

REF. NO.	DESCRIPTION	QTY.	PART NO.
1	Seal Punch – Wiper Seals	1	030.039
2	Seal Punch – Oil Seals	1	030.040
3	Service Stand (Feet)	1 pr.	037.109
4	Capscrew (M10 x 35)	4	024.131
	Allen Key (8 mm) (not shown)	1	020.010
	Allen key (6 mm) (not shown)	1	020.013